

# NEAW-LED

## Construction:

- Housing and chassis is steel
- Diffuser is vandal resistant acrylic

## Light Source:

- LED
- Dimming to 10% **Included**

## Notes:

- Integral mounting plate; Hardware include
- Mounts on a 2x4 jbox or 4" square post
- Optional two color choice of the frame and cover
- Optional battery backup available on fixtures 426 & larger
- UL and CUL listed **WET** location
- LED Components
  - Replaceable Module
  - CRI > 90
  - Universal 120/277 volt standard
  - 5-Year Warranty on LED Components

Type:	
Job Name:	

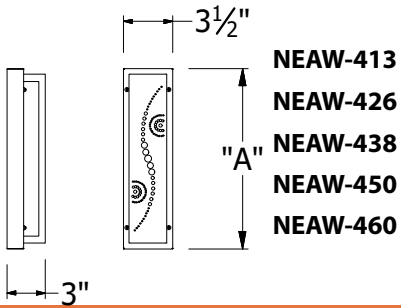

	DIM 'A'	Mount-Center
NEAW-413	13"	6.5"
NEAW-426	26"	13"
NEAW-438	38"	19"
NEAW-450	50"	25"
NEAW-460	60"	30"



## ORDERING INFORMATION

Example: NEAW-426-LED-O2C-3-B1-M16-DIM

### NEAW

Size	LED	Watts	Source Lumens	Dimming	Energy Star	Kelvin	Cage	Finish	Front Deco Finish	Options
						2 3000K 3 3500K 4 4000K		<b>B1</b> Satin Black <b>B2</b> Text Black <b>Z1</b> Satin Bronze <b>Z3</b> Text Bronze <b>W1</b> Yolk White <b>W2</b> Gloss White <b>T4</b> Shimmer Gray <b>M13</b> Anod Silver <b>T6</b> Pewter <b>W13</b> Pearl Beige	<b>B1</b> Satin Black <b>B2</b> Text Black <b>Z1</b> Satin Bronze <b>Z3</b> Text Bronze <b>W1</b> Yolk White <b>W2</b> Gloss White <b>T4</b> Shimmer Gray <b>M13</b> Anod Silver <b>T6</b> Pewter <b>W13</b> Pearl Beige	<b>DIM</b> LED dimming driver (0 - 10v) Dimming to 10% <b>(Included)</b>  <b>42</b> All Aluminum Construction
<b>413-LED</b>	<b>O1C</b>	9	1210	0-10v	NO			<b>Optional</b> (See Price List) <b>M16</b> Antique Brass <b>P2</b> Brushed Alum <b>P9</b> Brushed Nickel	<b>Optional</b> (See Price List) <b>M16</b> Antique Brass <b>P2</b> Brushed Alum <b>P9</b> Brushed Nickel	<b>Battery Backup Options</b> Available <b>(426 &amp; Larger)</b> <b>BB10</b> Battery backup unit providing 10 Watts (1170lm) for 90-Minute
<b>426-LED</b>	<b>O2C</b>	18	2420	0-10v	NO					
<b>438-LED</b>	<b>O3C</b>	27	3630	0-10v	NO					
<b>450-LED</b>	<b>O4C</b>	36	4840	0-10v	NO					
<b>460-LED</b>	<b>O5C</b>	45	6050	0-10v	NO					



28435 Industry Drive., Valencia, California 91355  
 West Coast Sales: 800-325-4448 / 661-257-0286 • fax 800-323-2346 / 661-257-0201  
 East Coast Sales: 866-350-0991 • fax 866-490-5754  
 www.lightwayind.com • sales@lightwayind.com

