

WITH LBC COVER

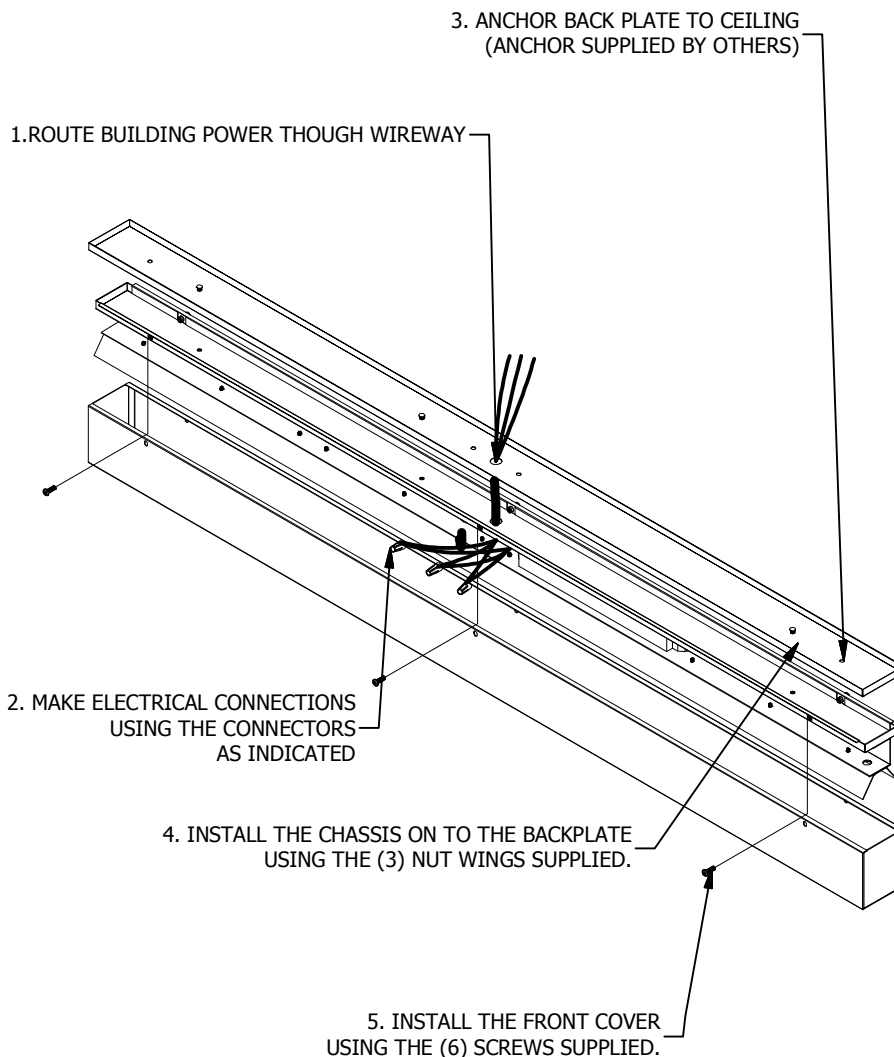

WITHOUT LBC COVER

1. **WARNING** - Turn off the power. Before starting the installation, locate the circuit breaker in the electrical circuit panel and switch the circuit off. *Turning off the light is not sufficient to prevent electrical shock.*
2. **Remove the old fixture.** If you are replacing an existing fixture, remove all components of the old fixture (cover, mounting plate, etc...), remove the old wire connectors, and expose the supply wiring from the electrical box.
3. **Connect the wires.** Use a wire stripper to remove the protective coating of the wires. Connect the grounding wire (green or bare copper wire) from the electrical box to the green wire of the fixture. Connect the white wire from the electrical box to the white wire of the fixture. Connect the black wire from the electrical box to the black wire(s) of the fixture.
4. **IMPORTANT.** Use only *UL Listed* connectors and tape to complete the installation. Carefully read and follow any additional installation instructions provided in this sheet.

LIGHTWAY INDUSTRIES

VALENCIA CA 91355

INSTALLATION INSTRUCTIONS

BY
M.
ROA

DESCRIPTION

PDLC-ELECTRICAL-INSTL-INSTR.

DATE
10/30/2017

PART NUMBER
62-218-00

REV
0